



621-010 Fliptop AIR – Roof systems for lengths up to 14m

Fliptop AIR is our pneumatic system, which opens from one side and uncovers it for loading. Fliptop AIR maneuvers with a pneumatic cylinder in the front or back depending on demand and space. Long roof systems are provided with pneumatic cylinders in both ends. Fliptop AIR has a mechanical locking system that locks the system when closed and automatically opens when the air is reinitiated. The lock maneuvers by the opening of the cylinder which means that a roof system with only one cylinder will only have one lock.

Ends and the longitudinal tube are made of galvanized steel. All the fulcrums are stored with bearing bushes and hinge points in the bottom have nipples. The pneumatic cylinder is included in the system, but the control valve is not. Optional several pneumatic components can be ordered, also complete valve systems with remote. Normally the system is operated with a hand lever valve 5/3, electric valve with single coil 5/2 or electric valve with double coil 5/3.

Working pressure is 9bar, variation pending on number of cylinders and length.
(example: 9m double layer tarpaulin = 6bar)

System:

621-010-6 Fliptop AIR Stand.

Max length 6,3m, Tubelength 6m straight, Cylinder in one gable

This includes: Gable without cylinder, Gable with cylinder, Central tube, Side tube, Screw kit, Tie down rings and Flow control valves in the cylinder.

621-010-8 Fliptop AIR Stand.

Max length 8,0m, Tubelength 8m prebended, Cylinder in both ends.

This includes: 2 st Gables with cylinder, Central tube, Side tube, Screw kit, Tie down rings and Flow control valves in the cylinders.

621-010-9 Fliptop AIR Stand.

Max length 9,0m, Middle support, Tubelength 9m straight, Cylinder in both ends.

This includes: 2 st Gables with cylinder, Central tube, Side tube, Screw kit, Tie down rings, Middle support with side tube connected and Flow control valves in the cylinders.

621-002-10 Fliptop AIR Stand.

Max length 10,0m, Middle support, Tubelength 10m straight, Cylinder in both ends.

This includes: 2 st Gables with cylinder, Central tube, Side tube, Screw kit, Tie down rings, Middle support with side tube connected and Flow control valves in the cylinders.

621-002-12 Fliptop AIR Stand.

Max length 12,0m, Middle support, Tubelength 6m straight, Cylinder in both ends.

This includes: 2 st Gables with cylinder, Central tube, Side tube, Screw kit, Tie down rings, Middle support with all tubes connected and Flow control valves in the cylinders.

621-002-14 Fliptop AIR Stand.

Max length 14,0m, Middle support, Tubelength 7m straight, Cylinder in both ends.

This includes: 2 st Gables with cylinder, Central tube, Side tube, Screw kit, Tie down rings, Middle support with all tubes connected and Flow control valves in the cylinders.

Tarpaulin:

188-000-1 Fliptop AIR Cover single layer. L=5m

188-000-11 Addition AIR for lengths over 5m.

188-000-5 Fliptop AIR Cover double layer. L=5m

188-000-55 Addition AIR for lengths over 5m.

188-000-6 Fliptop AIR Cover isolated. L=5m

188-000-66 Addition AIR for lengths over 5m.

This includes: Cover and mounting details.

Accessories:

188-569-2 Straight bracket for side tube.

188-570-2 Angle bracket for side tube.

233-112 QuickLock.

233-580 Stop sleeve, QuickLock.

621-171 Protective plate to gable, galvanized 3mm.

621-186 Protective plate to gable, galvanized 5mm.

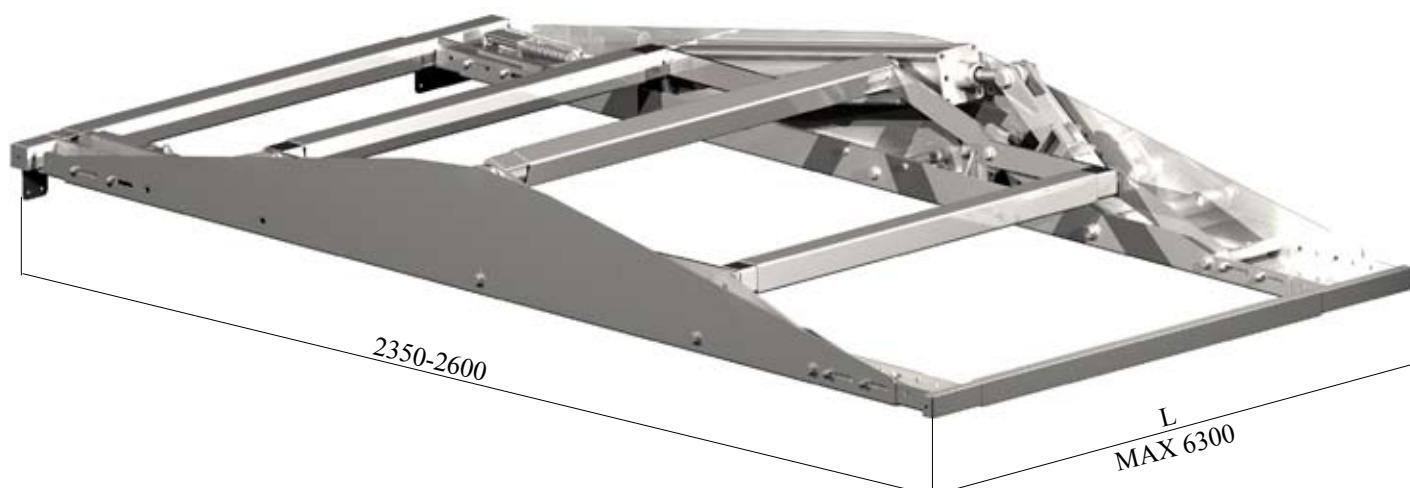

Article list - art.nr. 621-010-6

- 1 st **621-009** Gable with cylinder
Galvanized
72 kg



- 1 st **621-002-2** Gable
Galvanized
44 kg



- 1 st **12329 FZB** Steel tube 50x30x2
Galvanized L=6000
2,4 kg/m

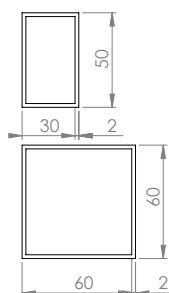

- 4 st **621-201** Steel tube 60x60x2
Galvanized L=6000
3,7 kg/m

- 1 st **621-301** Screw kit
- | | |
|--------------------|--------------|
| 2 st M8 Locknut | 4 st M8x20 |
| 2 st M8 Washer | 2 st M8x75 |
| 14 st M10 Locknut | 2 st M10x50 |
| 28 st M10 Washer | 12 st M10x75 |
| 2 st Tie down hook | |
| 4 st Rope clamps | |



Article list - art.nr. 621-010-8

- 2 st **621-009** Gable with cylinder
Galvanized
72 kg



- 1 st **12329 FZB** Steel tube 50x30x2
Galvanized L=8000
2,4 kg/m

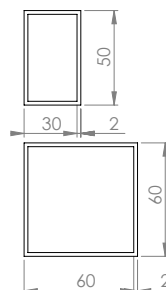

- 4 st **621-201** Steel tube 60x60x2
Galvanized L=8000
3,7 kg/m



- 1 st **621-301** Screw kit
- | | |
|--------------------|--------------|
| 2 st M8 Locknut | 4 st M8x20 |
| 2 st M8 Washer | 2 st M8x75 |
| 14 st M10 Locknut | 2 st M10x50 |
| 28 st M10 Washer | 12 st M10x75 |
| 2 st Tie down hook | |
| 4 st Rope clamps | |



Article list - art.nr. 621-010-9

- 2 st **621-009** Gable with cylinder
Galvanized
72 kg



- 1 st **621-003-1** Middle support
with side tube connected
Galvanized
21 kg



- 2 st **12329 FZB** Steel tube 50x30x2
Galvanized L=6000
2,4 kg/m

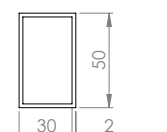

- 8 st **621-201** Steel tube 60x60x2
Galvanized L=6000
3,7 kg/m

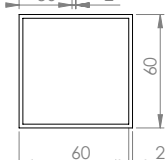

- 1 st **621-314** Screw kit
- | | |
|---------------------|--------------|
| 2 st M8 Locknut | 4 st M8x20 |
| 2 st M8 Washer | 2 st M8x75 |
| 18 st M10 Locknut | 4 st M10x50 |
| 36 st M10 Washer | 12 st M10x75 |
| 2 st Tie down hooks | 2 st M10x80 |
| 4 st Rope clamps | |

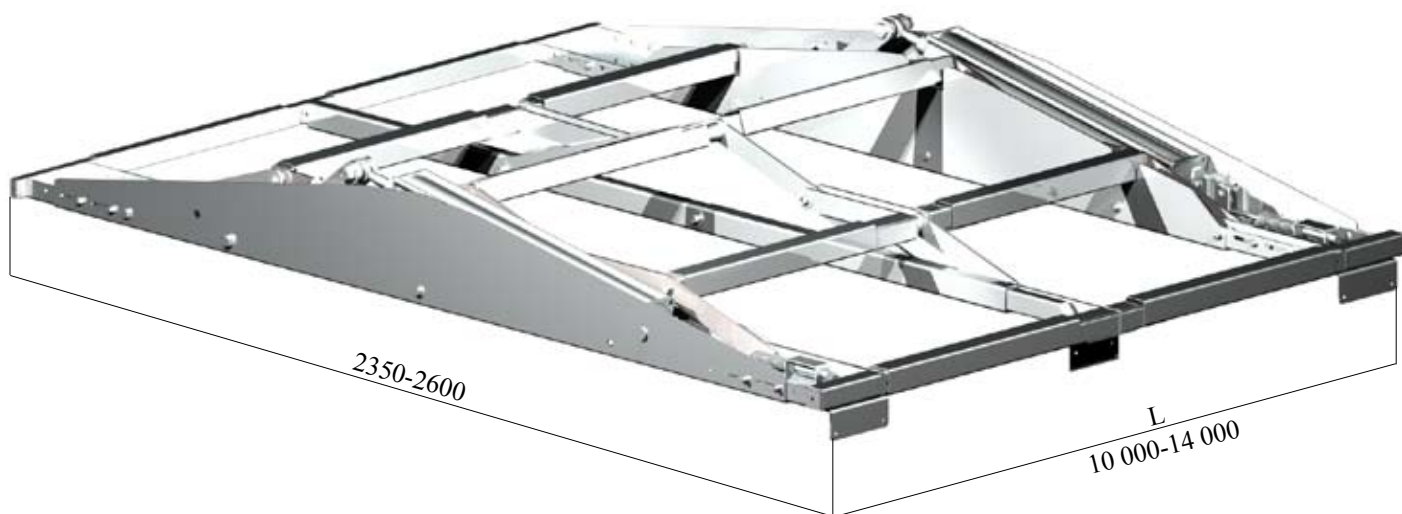

Article list - art.nr. 621-010-12

- 2 st **621-009** Gable with cylinder
Galvanized
72 kg



- 1 st **621-004** Middle support with
all tubes connected
Galvanized
40 kg



- 2 st **12329 FZB** Steel tube 50x30x2
Galvanized L=6000
2,4 kg/m

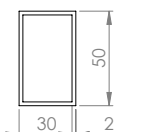

- 8 st **621-201** Steel tube 60x60x2
Galvanized L=6000 / L=8000
3,7 kg/m

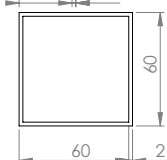

- 1 st **621-315** Screw kit
- | | |
|---------------------|--------------|
| 2 st M8 Locknut | 4 st M8x20 |
| 2 st M8 Washer | 2 st M8x75 |
| 28 st M10 Locknut | 4 st M10x50 |
| 56 st M10 Washer | 24 st M10x75 |
| 2 st Tie down hooks | |
| 4 st Rope clamps | |

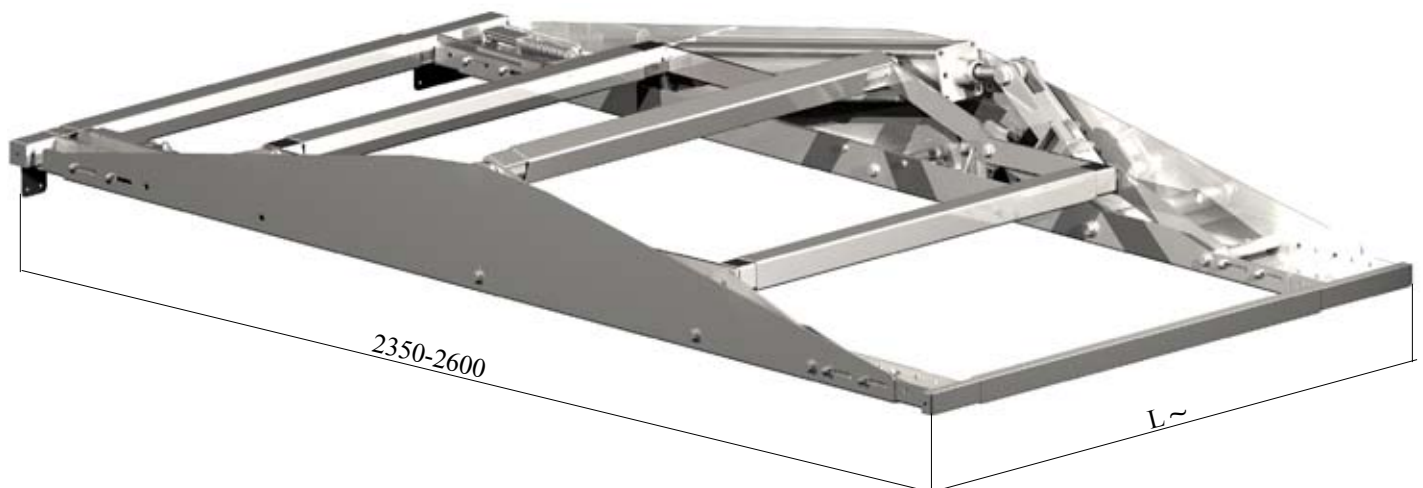

Article list - art.nr. 621-010 Accessories

621-171 Protective plate
Galvanized 5mm
14,5 kg

621-186 Protective plate
Galvanized 3mm
8,6 kg

188-569-2 Bracket
Galvanized
0,4 kg

188-570-2 Bracket
Galvanized
0,1 kg

233-112 QuickLock
Stainless steel
1 kg

233-580 Stop
Stainless steel
0,1 kg

